



US 20040245923A1

(19) **United States**

(12) **Patent Application Publication** (10) **Pub. No.: US 2004/0245923 A1**

Park et al.

(43) **Pub. Date: Dec. 9, 2004**

(54) **ORGANIC ELECTROLUMINESCENCE DEVICE EMPLOYING MULTI-LAYERED PIXEL ELECTRODE AND METHOD OF FABRICATING THE SAME**

(30) **Foreign Application Priority Data**

Jun. 3, 2003 (KR)..... 2003-0035760

Publication Classification

(75) Inventors: **Sang-Il Park**, Seoul (KR); **Hun-Jung Lee**, Annyang-si (KR); **Sang-Chul Kim**, Suwon-si (KR); **Chang-Soo Kim**, Suwon-si (KR)

(51) **Int. Cl.⁷** **H05B 33/08**; H05B 33/00
(52) **U.S. Cl.** **313/505**; 313/504; 313/500

Correspondence Address:
MCGUIREWOODS, LLP
1750 TYSONS BLVD
SUITE 1800
MCLEAN, VA 22102 (US)

(57) **ABSTRACT**

There is provided an organic electroluminescence device employing a multi-layered pixel electrode and a method of fabricating the same. The organic electroluminescence device comprises a substrate, a first pixel electrode located in a predetermined area on the substrate, and a second pixel electrode located on the first pixel electrode and entirely covering the first pixel electrode. Thus, the film breakdown due to the galvanic phenomenon is precluded.

(73) Assignee: **Samsung SDI Co., Ltd.**

(21) Appl. No.: **10/805,230**

(22) Filed: **Mar. 22, 2004**

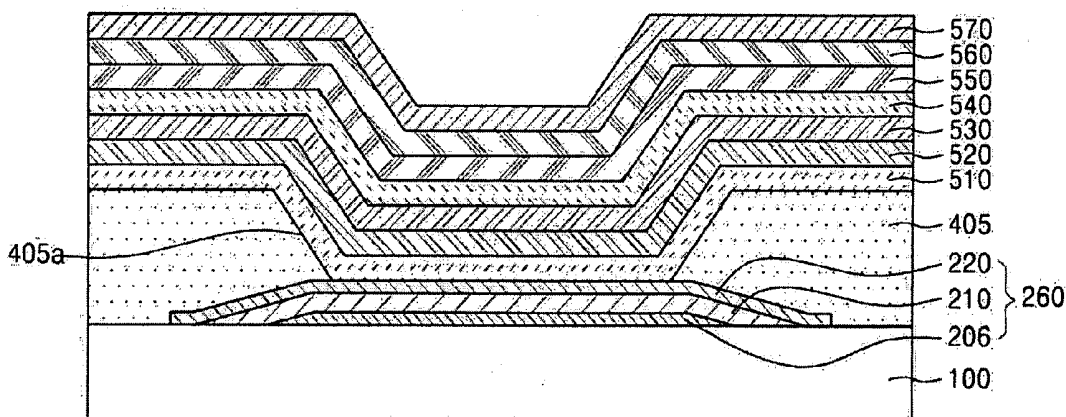

FIG. 1
(PRIOR ART)

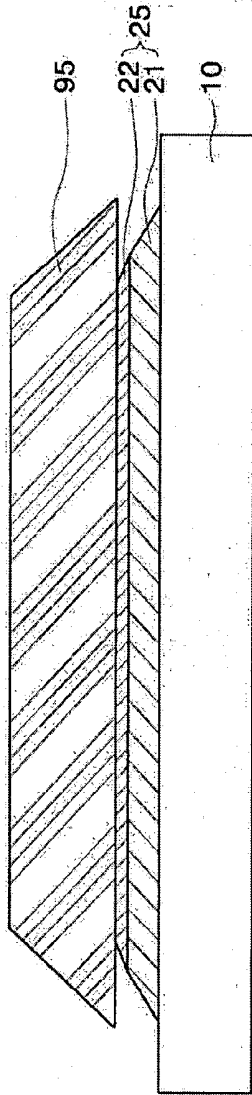

FIG. 2A

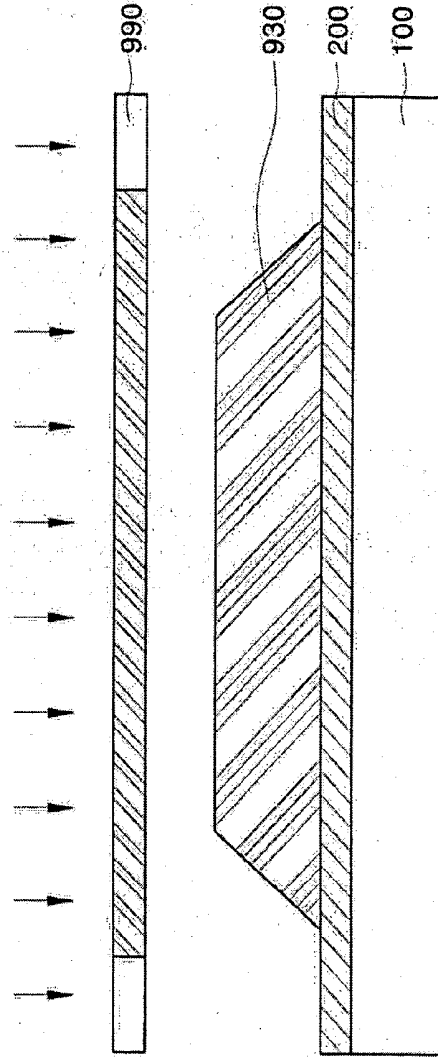

FIG. 2B

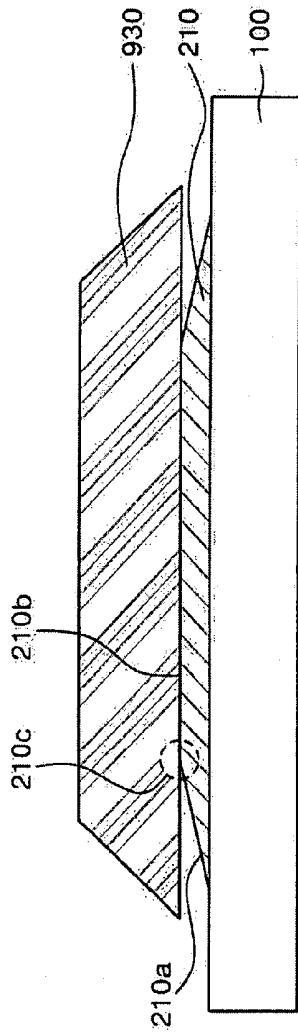

FIG. 2C

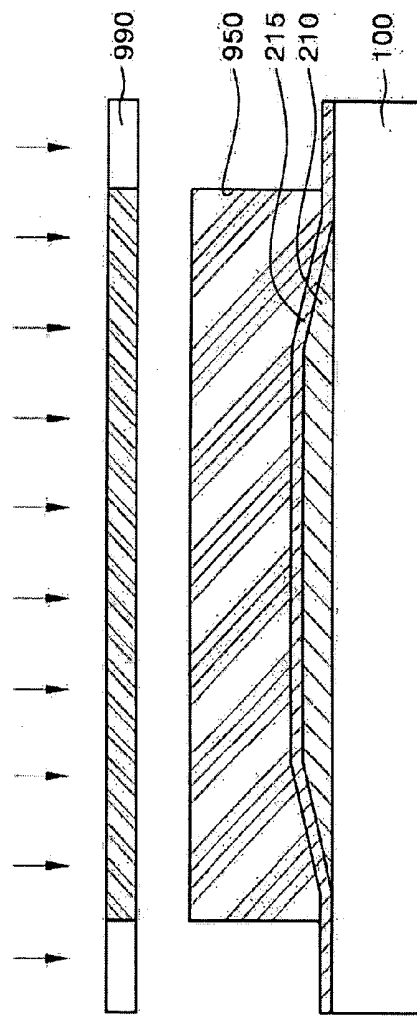

FIG. 2D

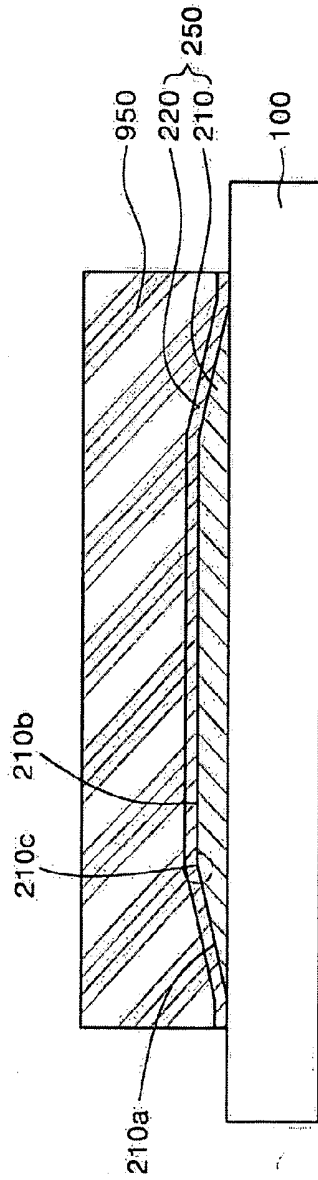

FIG. 2E

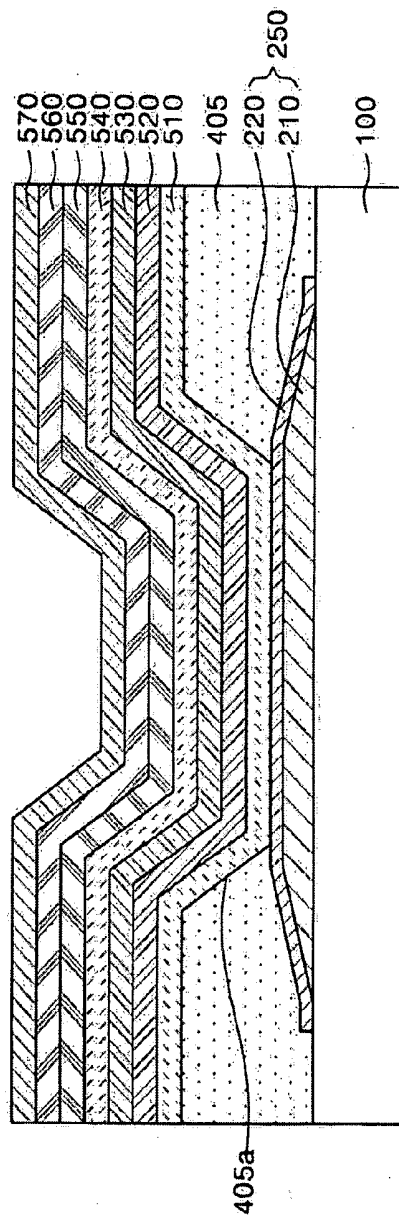
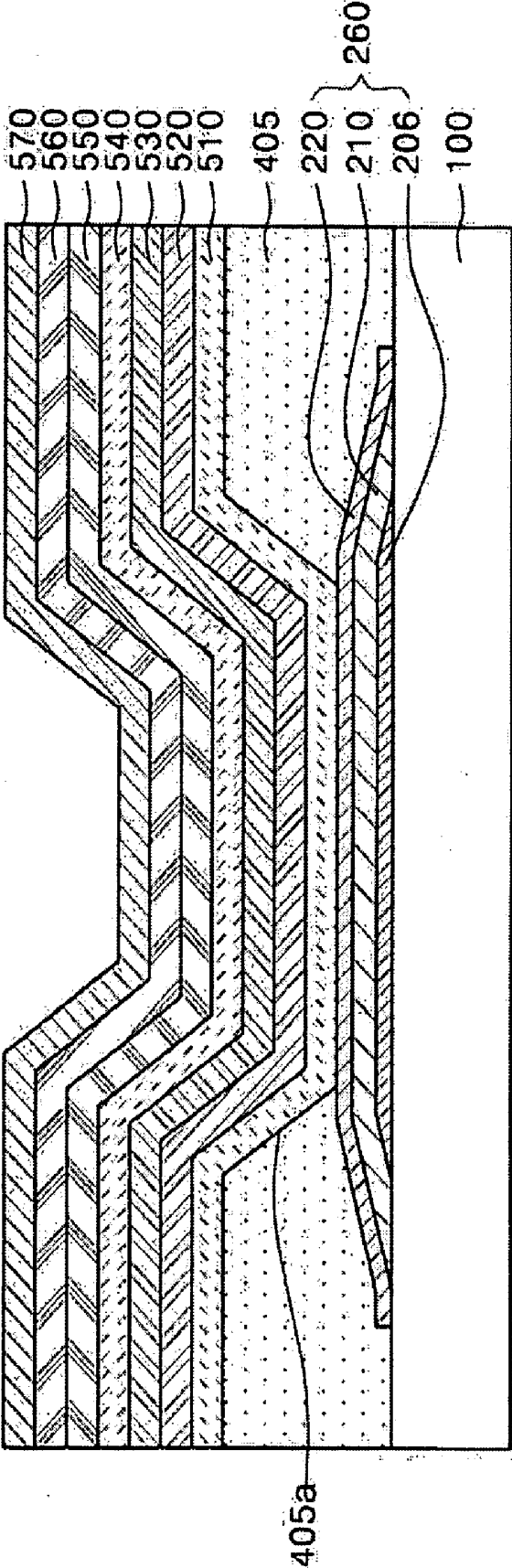

FIG. 3



**ORGANIC ELECTROLUMINESCENCE DEVICE
EMPLOYING MULTI-LAYERED PIXEL
ELECTRODE AND METHOD OF FABRICATING
THE SAME**

**CROSS-REFERENCE TO RELATED
APPLICATION**

[0001] This application claims the benefit of Korean Patent Application No. 2003-35760, filed on Jun. 3, 2003, the disclosure of which is incorporated herein by reference in its entirety.

Field of the Invention

[0002] The present invention relates to an organic electroluminescence device and a method of fabricating the same and, more particularly, to an organic electroluminescence device employing a multi-layered pixel electrode and a method of fabricating the same.

BACKGROUND OF THE INVENTION

[0003] An organic electroluminescence device may be classified into a bottom-emitting type and a top-emitting type and may also be classified into an active matrix type having a pixel driving circuit in each pixel and a passive matrix type. Where the organic electroluminescence device is a bottom-emitting type, as well as an active matrix type, the pixel driving circuit and various kinds of wiring for applying voltages to the pixel driving circuit may take up space in a pixel, and an aperture ratio may be restricted. Accordingly, in order to improve the aperture ratio, the top-emitting type is introduced.

[0004] In the top-emitting type organic electroluminescence device, a conductive material having improved reflection characteristics and a suitable work function may be used for a pixel electrode. However, currently there isn't any applicable single material that satisfies such characteristics. Therefore, in order to satisfy the characteristics of the pixel electrode of the top-emitting type organic electroluminescence device, a multi-layered structure is adopted to the pixel electrode.

[0005] Korean patent application No. 2000-0058739 discloses an organic electroluminescence device of a top-emitting type. The organic electroluminescence device comprises a substrate, a reflecting plate formed on a top surface of the substrate, a first electrode formed on the top surface of the reflecting plate, an emitting layer formed on a top surface of the first electrode, and a second electrode formed on the emitting layer. Thus, by forming the reflecting plate on the top surface of the substrate, a structure in which the light emitted from the emitting layer is reflected to the opposite direction of the substrate, that is, the top-emitting type organic electroluminescence device is embodied.

[0006] FIG. 1 is a cross-sectional view of a method of fabricating an top-emitting type organic electroluminescence device employing a multi-layered pixel electrode according to the prior art.

[0007] Referring to FIG. 1, a first pixel electrode film and a second pixel electrode film are successively formed on a substrate 10. A photoresist pattern 95 is formed on the second pixel electrode film. The second pixel electrode film and the first pixel electrode film are etched in turn using the

photoresist pattern 95 as a mask. Subsequently, the photoresist pattern 95 is removed. Thus, a pixel electrode 25 consisting of the second pixel electrode 22 and the first pixel electrode 21 is formed. Etching the second pixel electrode film and the first pixel electrode film in turn is generally performed by using a wet etching solution, and the photoresist pattern 95 is removed by using a stripping solution.

[0008] In the meantime, a galvanic phenomenon occurs when two materials whose electromotive forces are different are simultaneously exposed to an electrolyte solution. As a result, the material having the greater electromotive force is corroded.

[0009] In general, since the first pixel electrode 21 is a reflecting electrode and the second pixel electrode 22 is a transparent electrode, the pixel electrodes 21, 22 are formed by using different materials. Accordingly, electromotive forces of the pixel electrodes 21, 22 can be different. Consequently, the galvanic phenomenon occurs between the first pixel electrode 21 and the second pixel electrode 22 when the first pixel electrode 21 and the second pixel electrode 22 are simultaneously exposed to the etching solution or the stripping solution, that is, the electrolyte solution. As a result, an electrode having the greater electromotive force between the second pixel electrode 22 and the first pixel electrode 21 is corroded, resulting in a break down of the films of the pixel electrode 25.

SUMMARY OF THE INVENTION

[0010] Thus, the present invention is devised to solve at least the above problem. Accordingly, an aspect of the present invention is to provide an organic electroluminescence device and a fabricating method of the same to prevent a film of the pixel electrode from being broken down by precluding a galvanic phenomenon when forming the pixel electrode.

[0011] In order to achieve an aspect of the present invention, there is provided an organic electroluminescence device employing a multi-layered pixel electrode. The organic electroluminescence device comprises a substrate, a first pixel electrode located in a predetermined area on the substrate, and a second pixel electrode located on the first pixel electrode and entirely covering the first pixel electrode.

[0012] The first pixel electrode may have a side tapered toward upper part thereof. Furthermore, the first pixel electrode may comprise at least one material selected from a group consisting of aluminum (Al), aluminum alloy, silver (Ag) and silver alloy.

[0013] The second pixel electrode may comprise at least one material selected from a group consisting of indium tin oxide (ITO), indium zinc oxide (IZO), nickel (Ni), nickel oxide, platinum (Pt), platinum oxide, gold (Au), gold oxide, iridium (Ir), iridium oxide, chrome (Cr) and chrome oxide.

[0014] In addition, the first pixel electrode may comprise aluminum-neodymium (AlNd); and the second pixel electrode may comprise indium tin oxide (ITO).

[0015] The organic electroluminescence device may further comprise a third pixel electrode located between the first pixel electrode and the substrate, where the first pixel electrode entirely covers the third pixel electrode.

[0016] A side of the third pixel electrode may be tapered toward its upper part. The third pixel electrode may comprise at least one material selected from a group consisting of indium tin oxide (ITO), indium zinc oxide (IZO), nickel (Ni), nickel oxide, platinum (Pt), platinum oxide, gold (Au), gold oxide, iridium (Ir), iridium oxide, chrome (Cr) and chrome oxide.

[0017] In addition, the first pixel electrode may comprise aluminum-neodymium (AlNd), and both the second pixel electrode and the third pixel electrode may comprise indium tin oxide (ITO).

[0018] In order to achieve an aspect of the present invention, there is provided a method of fabricating the organic electroluminescence device employing a multi-layered pixel electrode. The fabricating method comprises providing a substrate, forming a first pixel electrode in a predetermined area on the substrate, and forming a second pixel electrode on the first pixel electrode to entirely cover the first pixel electrode.

[0019] The first pixel electrode may be formed to have a side tapered toward its upper part. The first pixel electrode may be formed of at least one material selected from a group consisting of aluminum, aluminum alloy, silver and silver alloy.

[0020] The second pixel electrode may be formed of at least one material selected from a group consisting of indium tin oxide (ITO), indium zinc oxide (IZO), nickel, nickel oxide, platinum, platinum oxide, gold, gold oxide, iridium, iridium oxide, chrome and chrome oxide.

[0021] In addition, the first pixel electrode may be formed of the aluminum-neodymium (AlNd), and the second pixel electrode formed of indium tin oxide (ITO).

[0022] The fabricating method may further comprise forming a third pixel electrode in the predetermined area on the substrate before the first pixel electrode is formed, and the first pixel electrode is formed to entirely cover the third pixel electrode.

[0023] The third pixel electrode may be formed to have a side tapered toward its upper part.

[0024] Further, the third pixel electrode is formed of at least one material selected from a group consisting of indium tin oxide (ITO), indium zinc oxide (IZO), nickel, nickel oxide, platinum, platinum oxide, gold, gold oxide, iridium, iridium oxide, chrome and chrome oxide. Third pixel electrode may be formed of indium tin oxide (ITO), the first pixel electrode formed of aluminum-neodymium (AlNd), and the second pixel electrode formed of indium tin oxide (ITO).

BRIEF DESCRIPTION OF THE DRAWINGS

[0025] The above and other features and advantages of the present invention will become more apparent to those of ordinary skill in the art by describing in detail preferred embodiments thereof with reference to the attached drawings.

[0026] FIG. 1 is a cross-sectional view for explaining a method of fabricating an organic electroluminescence device employing a multi-layered pixel electrode according to the Prior Art.

[0027] FIGS. 2a to 2e are cross-sectional views illustrating a method of fabricating an organic electroluminescence device employing a two-layered pixel electrode according to a first embodiment of the present invention.

[0028] FIG. 3 is a cross-sectional view for illustrating a method of fabricating an organic electroluminescence device employing a three-layered pixel electrode according to a second embodiment of the present invention.

DETAILED DESCRIPTION OF THE INVENTION

[0029] To explain the present invention more specifically, embodiments of the present invention will be described in detail below with reference to the accompanying drawings. However, the present invention is not restricted by the embodiments described herein but can be embodied in other forms.

[0030] In the drawings, when a layer lies "on" another layer or a substrate, it is understood that the layer may be formed directly on the other layer or the substrate, or another layer may be interposed between them. Throughout the specification, the same reference numerals represent the same components.

[0031] FIGS. 2a to 2e are cross-sectional views for explaining a method of fabricating an organic electroluminescence device employing a two-layered pixel electrode according to a first embodiment of the present invention.

[0032] Referring to FIG. 2a, a first pixel electrode film 200 is formed on a substrate 100. In the case of an active matrix organic electroluminescence device, the substrate 100 may include a thin film transistor (not shown) formed by a conventional method. A first photoresist film may be formed on the first pixel electrode film 200, and thereafter the first photoresist film is exposed and developed by using a photomask 990 so that a first photoresist pattern 930 is formed. When the first photoresist film is exposed, the exposure may be excessively performed. Thus, not only may a pattern width of the first photoresist pattern 930 be smaller than a width of a pattern drawn in the photomask 990, but a side of the first photoresist pattern 930 may also be tapered toward its upper part.

[0033] Referring to FIG. 2b, by etching the first pixel electrode film (200 in FIG. 2a) using the first photoresist pattern 930 as a mask, a first pixel electrode 210 is formed. When the first pixel electrode film (200 in FIG. 2a) is etched, the etching may be performed excessively. Thus, a pattern width of the first pixel electrode 210 can be smaller than a pattern width of the first photoresist pattern 930. Moreover, as described above, by making a side of the first photoresist pattern 930 tapered toward its upper part, a side 210a of the first pixel electrode 210 can also be tapered toward its upper part. In other words, an angle of an edge 210c through which the side 210a and an upper face 210b of the first pixel electrode 210 meet each other may be obtuse. Further, the taper may be dull.

[0034] The first pixel electrode 210 may be formed of metal that has excellent reflectivity. According to an embodiment of the invention, the excellent reflectivity means 60% or more reflectivity. The first pixel electrode 210 may be formed of at least one material selected from a group consisting of aluminum (Al), aluminum alloy, silver (Ag)

and silver alloy. Also, the first pixel electrode **210** may be formed to have thickness of 50 to 300 nanometers.

[0035] Referring to FIG. 2c, on the substrate on which the first pixel electrode **210** is formed, a second pixel electrode film **215** may be formed. A second photoresist film is formed on the second pixel electrode film **215**. Successively, a second photoresist pattern **950** may be formed by exposing and developing the second photoresist film using the same photomask **990** as the photomask (**990** in FIG. 2a) that exposed the first photoresist film. Unlike the first photoresist pattern (**930** in FIG. 2a), the second photoresist pattern **950** may be formed to have almost the same pattern width as the width of the pattern drawn on the photomask **990**.

[0036] Referring to FIG. 2d, the second pixel electrode film (**215** in FIG. 2c) may be etched with a wet etching solution by using the second photoresist pattern **950** as a mask. Thus, a second pixel electrode **220** may be formed to entirely cover the first pixel electrode **210**. Subsequently, a pixel electrode **250** consisting of the first pixel electrode **210** and the second pixel electrode **220** is formed by removing the second photoresist pattern **950** with a stripping solution.

[0037] As described above, in forming the first pixel electrode **210**, by performing an excessive exposure and an excessive etching, a pattern width of the first pixel electrode **210** may be formed to be smaller than a pattern width drawn on the photomask (**990** in FIG. 2a). A pattern width of the second pixel electrode **220** may be formed to almost the same as the pattern width drawn on the photomask (**990** in FIG. 2c). Consequently, the second pixel electrode **220** may be formed to entirely cover the first pixel electrode **210**. Thus, exposure of the first pixel electrode **210** and the second pixel electrode **220** simultaneously to a electrolyte solution i.e. the wet etching solution or the stripping solution, can be prevented. Accordingly, the galvanic phenomenon between the first pixel electrode **210** and the second pixel electrode **220** can be precluded. As a result, film breakdowns of the pixel electrode **250** can be lessened or prevented.

[0038] Furthermore, in forming the first pixel electrode **210**, by making the side **210a** tapered toward its upper part, breaking the second pixel electrode **220** on the edge **210c** of the first pixel electrode **210** may be prevented. Concurrently, since the first pixel electrode **210** and the second pixel electrode **220** may be formed by using the same photomask (**990** in FIGS. 2a and 2c), a processing cost can be lowered compared with a case of using different photomasks.

[0039] When the pixel electrode **250** is an anode, the second pixel electrode **220** may be formed by using a conductive material that has a work function of 4.5 to 5.8 eV so that a hole injection may be easily performed. Accordingly, the second pixel electrode **220** may be formed of at least one material selected from a group consisting of indium tin oxide (ITO), indium zinc oxide (IZO), nickel (Ni), nickel oxide, platinum (Pt), platinum oxide, gold (Au), gold oxide, iridium (Ir), iridium oxide, chrome (Cr) and chrome oxide. According to an embodiment of the invention, the second pixel electrode **220** may be formed to have thickness of 1 to 30 nanometers.

[0040] The first pixel electrode **210** may be comprised of aluminum-neodymium (AlNd), and the second pixel electrode **220** comprised of indium tin oxide (ITO).

[0041] Referring to FIG. 2e, a pixel-defined layer **405** having an opening **405a** for exposing an upper surface of the second pixel electrode **220** is formed on the second pixel

electrode **220**. An organic film including at least an organic emitting layer **530** is formed on the exposed second pixel electrode **220** and on the pixel-defined layer **405**. The organic film may further comprise at least one layer selected from a group consisting of a hole injecting layer **510**, a hole transporting layer **520**, a hole blocking layer **540**, an electron transporting layer **550** and an electron injecting layer **560**. In order to form the organic film, a conventional method such as a thermal evaporation deposition can be used.

[0042] Subsequently, a transparent electrode **570** may be formed on the organic film, such as to by using a thermal evaporation deposition, a sputtering, etc. Thereafter, the substrate **100** on which the transparent electrode **570** is formed is encapsulated. The encapsulation can be fulfilled by attaching an encapsulation plate formed of glass or transparent plastic to the substrate **100** using adhesives, and by hardening the adhesives using ultraviolet rays or heats. Other encapsulation plate materials, adhesives and adhesive hardening materials may also be used.

[0043] FIG. 3 is a cross-sectional view for explaining a method of fabricating an organic electroluminescence device employing a three-layered pixel electrode according to a second embodiment of the present invention. The method according to the present embodiment is similar to the method according to the first embodiment except that the pixel electrode has three layers.

[0044] Referring to FIG. 3, a substrate **100** is provided, and a third pixel electrode **206** is formed on the substrate **100**. The third pixel electrode **206** may be formed to have a side tapered toward its upper part. The first pixel electrode **210** is formed on the third pixel electrode **206** to entirely cover the third pixel electrode **206**. Thus, film breakdown due to the galvanic phenomenon between the third pixel electrode **206** and the first pixel electrode **210** can be prevented. Except those described above, the organic electroluminescence device employing the three-layered pixel electrode **260** may be fabricated in the same method as those described in the first embodiment.

[0045] The third pixel electrode **206** may be formed of at least one material selected from a group consisting of indium tin oxide (ITO), indium zinc oxide (IZO), nickel (Ni), nickel oxide, platinum (Pt), platinum oxide, gold (Au), gold oxide, iridium (Ir), iridium oxide, chrome (Cr), and chrome oxide. The third pixel electrode **206** may be formed by using ITO. Alternatively, the third pixel electrode **206** may be formed by using ITO, the first pixel electrode **210** formed by using aluminum-neodymium (AlNd), and the second pixel electrode **220** formed by using indium tin oxide (ITO).

[0046] According to the present invention as described in detail so far, in forming the multi-layered pixel electrode, the film breakdown due to the galvanic phenomenon is precluded. As a result, defects of the organic electroluminescence device can be decreased, and yield and productivity are improved so that a production cost can be lowered.

What is claimed is:

1. An organic electroluminescence device, comprising:
 - a substrate;
 - a first pixel electrode located in a predetermined area on the substrate; and
 - a second pixel electrode located on the first pixel electrode and entirely covering the first pixel electrode.

2. The organic electroluminescence device according to claim 1, wherein the first pixel electrode has a side tapered toward an upper part thereof.

3. The organic electroluminescence device according to claim 1, wherein the first pixel electrode is comprised of at least one material selected from a group consisting of aluminum, aluminum alloy, silver and silver alloy.

4. The organic electroluminescence device according to claim 1, wherein the second pixel electrode is comprised of at least one material selected from a group consisting of indium tin oxide (ITO), indium zinc oxide (IZO), nickel, nickel oxide, platinum, platinum oxide, gold, gold oxide, iridium, iridium oxide, chrome and chrome oxide.

5. The organic electroluminescence device according to claim 1, wherein the first pixel electrode is comprised of the aluminum-neodymium (AlNd), and the second pixel electrode is comprised of indium tin oxide (ITO).

6. The organic electroluminescence device according to claim 1, further comprising a third pixel electrode located between the first pixel electrode and the substrate; and where the first pixel electrode entirely covers the third pixel electrode.

7. The organic electroluminescence device according to claim 6, wherein the third pixel electrode has a side tapered toward an upper part thereof.

8. The organic electroluminescence device according to claim 6, wherein the third pixel electrode is comprised of at least one material selected from a group consisting of indium tin oxide (ITO), indium zinc oxide (IZO), nickel, nickel oxide, platinum, platinum oxide, gold, gold oxide, iridium, iridium oxide, chrome and chrome oxide.

9. The organic electroluminescence device according to claim 6, wherein the first pixel electrode is comprised of aluminum-neodymium (AlNd); and both the second pixel electrode and the third pixel electrode are comprised of indium tin oxide (ITO).

10. A method of fabricating an organic electroluminescence device, comprising the steps of:

providing a substrate;

forming a first pixel electrode in a predetermined area on the substrate; and

forming a second pixel electrode on the first pixel electrode to entirely cover the first pixel electrode.

11. The method of fabricating the organic electroluminescence device according to claim 10, wherein the first pixel electrode is formed to have a side tapered toward an upper part thereof.

12. The method of fabricating the organic electroluminescence device according to claim 10, wherein the first pixel electrode and the second pixel electrode are formed by using a same photomask.

13. The method of fabricating the organic electroluminescence device according to claim 10, wherein the first pixel electrode is formed of at least one material selected from a group consisting of aluminum, aluminum alloy, silver and silver alloy.

14. The method of fabricating the organic electroluminescence device according to claim 10, wherein the second pixel electrode is formed of at least one material selected from a group consisting of indium tin oxide (ITO), indium zinc oxide (IZO), nickel, nickel oxide, platinum, platinum oxide, gold, gold oxide, iridium, iridium oxide, chrome and chrome oxide.

15. The method of fabricating the organic electroluminescence device according to claim 10, wherein the first pixel electrode is formed of the aluminum-neodymium (AlNd); and the second pixel electrode is formed of indium tin oxide (ITO).

16. The method of fabricating the organic electroluminescence device according to claim 10, further comprising the step of forming a third pixel electrode in the predetermined area on the substrate before the first pixel electrode is formed; and the first pixel electrode is formed so as to entirely cover the third pixel electrode.

17. The method of fabricating the organic electroluminescence device according to claim 16, wherein the third pixel electrode is formed to have a side tapered toward an upper part thereof.

18. The method of fabricating the organic electroluminescence device according to claim 16, wherein the third pixel electrode is formed of at least one material selected from a group consisting of indium tin oxide (ITO), indium zinc oxide (IZO), nickel, nickel oxide, platinum, platinum oxide, gold, gold oxide, iridium, iridium oxide, chrome and chrome oxide.

19. The method of fabricating the organic electroluminescence device according to claim 16, wherein third pixel electrode is formed of indium tin oxide (ITO); the first pixel electrode is formed of aluminum-neodymium (AlNd); and the second pixel electrode is formed of indium tin oxide (ITO).

20. An organic electroluminescence device, comprising:
a substrate;

a first pixel electrode located in a predetermined area on the substrate, where the first pixel electrode has a side tapered toward an upper part thereof;

a second pixel electrode located on the first pixel electrode and entirely covering the first pixel electrode; and

a third pixel electrode located between the first pixel electrode and the substrate, where the first pixel electrode entirely covers the third pixel electrode, and where the third pixel electrode has a side tapered toward an upper part thereof.

21. A method of fabricating an organic electroluminescence device, comprising the steps of:

providing a substrate;

forming a first pixel electrode in a predetermined area on the substrate, where the first pixel electrode is formed to have a side tapered toward an upper part thereof;

forming a second pixel electrode on the first pixel electrode to entirely cover the first pixel electrode; and

forming a third pixel electrode in a predetermined area on the substrate before the first pixel electrode is formed, where the first pixel electrode is formed so as to cover the third pixel electrode and the third pixel electrode is formed to have a side tapered toward an upper part thereof.

专利名称(译)	采用多层像素电极的有机电致发光器件及其制造方法		
公开(公告)号	US20040245923A1	公开(公告)日	2004-12-09
申请号	US10/805230	申请日	2004-03-22
申请(专利权)人(译)	三星SDI CO. , LTD.		
当前申请(专利权)人(译)	三星DISPLAY CO. , LTD.		
[标]发明人	PARK SANG IL LEE HUN JUNG KIM SANG CHUL KIM CHANG SOO		
发明人	PARK, SANG-IL LEE, HUN-JUNG KIM, SANG-CHUL KIM, CHANG-SOO		
IPC分类号	H05B33/26 H01L51/52 H05B33/00 H05B33/08 H05B33/10 H05B33/12 H05B33/28		
CPC分类号	H01L51/5206 H01L51/5221 H01L2251/5315 H05B33/10 H05B33/28 H01L51/5209 H01L51/5218 H01L51/5234		
优先权	1020030035760 2003-06-03 KR		
其他公开文献	US7298083		
外部链接	Espacenet USPTO		

摘要(译)

提供一种采用多层像素电极的有机电致发光器件及其制造方法。有机电致发光器件包括基板，位于基板上的预定区域中的第一像素电极，以及位于第一像素电极上并完全覆盖第一像素电极的第二像素电极。因此，排除了由于电偶现象引起的膜破裂。

